

COLOR TELEVISION

SERVICE MANUAL

SERVICE MANUAL



TK2026

IS-TV040919

CONTENTS

Safety instruction	1
General instruction	1
Alignment instructions	2
Alignment methods	2
Block diagram	14
Main IC	15
Wiring diagram	19
Schematic diagram	20

Note: This service manual is only for professional service personnel's reference. Before servicing the unit, please read the following items carefully.

Safety instruction

1. X-RAY radiation precaution

1.1 Excessive voltage will cause harmful X-ray. To avoid this radiation hazard, the high voltage should fall within the limitation. The appliance works at AC 120V, 60Hz. The high voltage of zero beam current (brightness, contrast and color is min) should be within 27.5kV on condition that the main power (B+) voltage is AC120V. And it should not exceed 29.5kV in any condition (21"SF CRT).

When servicing, please refer to the HIGH VOLTAGE CHECK procedure this service manual before check the high voltage and the high voltage meter should be reliable and accurate.

* Keep the main power voltage at 120V when checking the high voltage.

1.2 The primary source of X-RAY RADIATION is the CRT. The CRT of this TV set have gotten the approval of safety authentication inspection. The replacement CRT should be exactly the same type and specification CRT which has gotten a similar safety approval, and check the high voltage according to the HIGH VOLTAGE CHECK procedure.

2. Safety precaution

- a. Since the power supply circuit of this receiver is directly connected to the AC power line, an isolation transformer is necessary during dynamic service to avoid possible shock hazard.
- b. Always discharge the graphite layer conductor when moving the CRT.
- c. Disconnect the power cord before replacing parts.
- d. When replacing high-power resistor, keep the resistor 10 mm away from the circuit board.

3. Component safety precaution

Many electrical and mechanical parts in the chassis have special safety-related characteristics. These characteristics are often passed unnoticed by a visual inspection. Replacement parts which have these special safety characteristics are identified in this manual and its supplement electrical components having such features are shaded or marked by  on the schematic diagram and the parts list. Before replacing any of these components, read the parts list in this manual carefully. The use of substitute replacement parts which do not have the same characteristic as specified in the parts list may create shock, fire, X-RAY RADIATION or other hazards.

General instruction

1. Copy the standard model data to let EEPROM (N702 24C08)of the chassis have those data before placing it on the unit, do "factory adjustment" if necessary. If use a blank EEPROM directly, you should preset IIC data and then do other common adjustment.

2.The adjustment should be done under following circumstances without additional instruction

- a) Alternating current 120V/60Hz
- b) Preheat at least 30 min

3.The unit has auto degaussing circuit, the auto degaussing process can be finished within 2s when the main power. Only when turn on the unit at least 20min after last time turn off TV does the auto degaussing circuit work.

4. If the CRT with magnetism affects color purity and convergence, when the auto degaussing eraser. if the color purity and convergence are still not very good, then corresponding adjustment should be done. Refer to picture tube adjustment method for adjustment.

Alignment instruction

1. Debugging item

- a) adjust mode instruction
- b) B+ voltage adjustment
- c) RFAGC voltage adjustment
- d) Focus adjustment
- e) Screen-grid voltage white balance, sub brightness adjustment
- f) filed scan center, line , amplitude adjustment
- g) H-scan center adjustment

2. Alignment flow

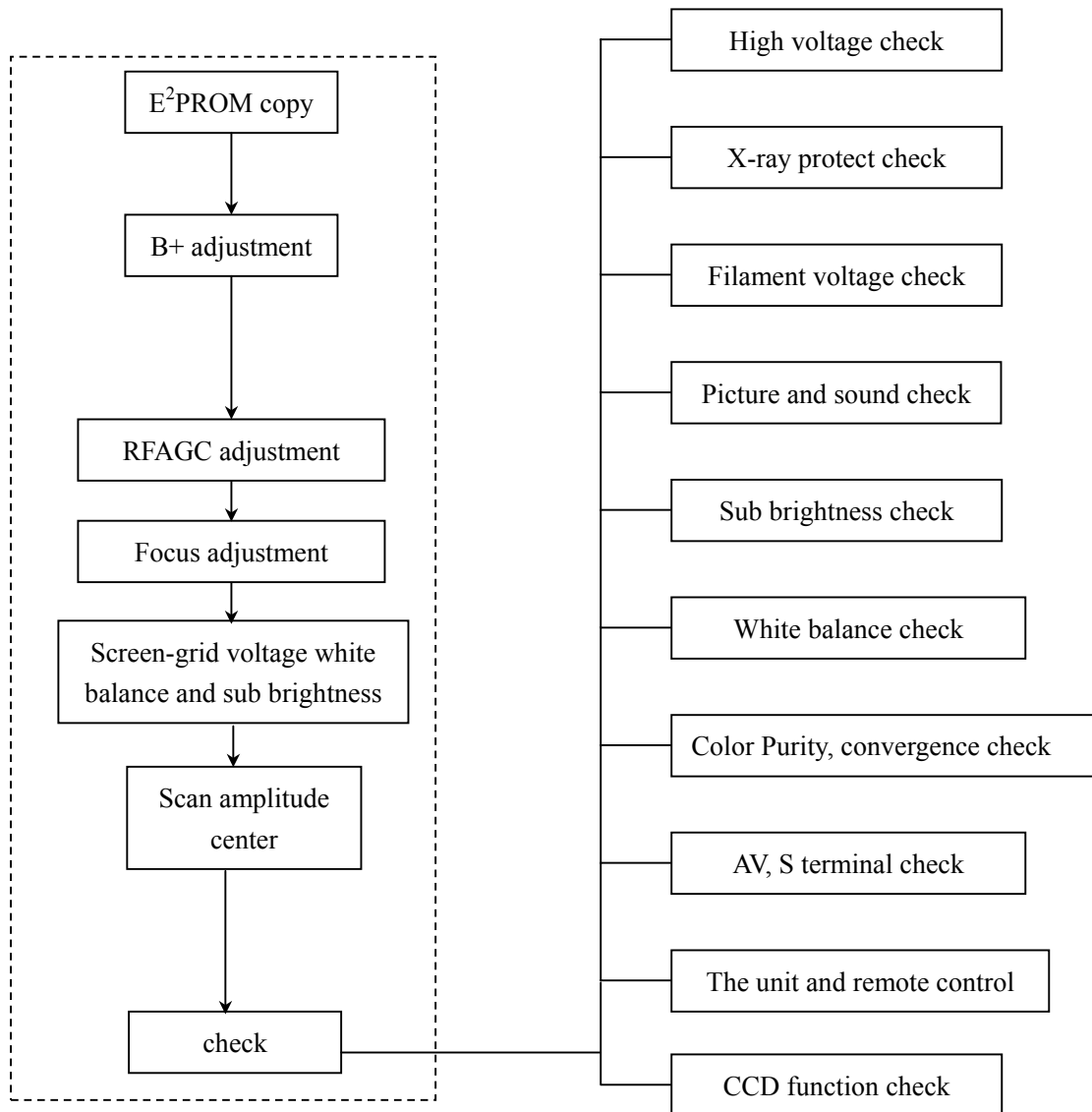

Fig-1 alignment flow

3. Factory menu adjustment methods

3.1 Enter/exit factory adjustment method

Use remote control, press "MENU" button, then press 6483, "Test" will appear on screen to show that you have entered the factory adjustment method, press "STANDBY" to exit it. Use factory remote control, press the "PRESET" and "TEST" button, then the screen display "Test" which means you have entered into the factory adjustment mode, press the "TEST" or "STANDBY" to exit.

3.2 select adjustment item and adjust data

After entering factory adjustment mode, press 1-4 number buttons to select menu 1- menu 4; to enter into MENU0, MENU5-MENU9, you may return to MENU1-MENU4 or just after you enter into "Test" interface, quickly press "CHILD LOCK" button and then the number button (0,5-9) to enter into relative menus. Press "CH+" and "CH-" to select and "V+" and "V-" to adjust.

At "program" item of MENU1, press "V+", "V-" or the number button 0-9 to switch channel, only after exit the "program" item you can do other operation.

3.3 User purview

- a). Factory adjustment mode menu1-menu4: only debugging worker, service checker, craftwork technician, designer may operate.
- b). Factory adjustment mode menu0, menu5-menu9: only craftwork technician, designer may operate.

4. Alignment methods

4.1 B+ voltage adjustment

- a) Connect B+ point with a digital voltmeter to measure the negative pole of VD524
- b) Receive PHILIPS test pattern signal and set the picture to standard.
- c) Adjust VR501 to let B+ voltage be appropriate value (see below chart).

B+ voltage requirement

CRT brand	CRT model	B+ (V)
NOVEL	54SX503Y22-DC01	107
IRICO	54SX538Y22-DC01	107
SAMSUNG	A51KQK99X01	105.5

4.2 AGC adjustment

- a) receive VHF-H band,60 dB RF signal of color bar.
- b) Select factory menu2 of "AGC".
- c) Adjust AGC-TOP to let the picture just without noisy, and the voltage of tuner AGC is $3.7V \pm 0.1V(DC)$.
- d) exit factory menu

4.3 Normal temperature aging

- a) do not receive signals.
- b) under "Test" condition, set the accelerator to an appropriate point for aging.

4.4 Accelerator adjustment

- a) do not receive signals;
- b) select "SC" of factory menu3 to let the field scanning stop working.
- c) set the picture to standard, adjust acceleration potentiometer to let bright lines just appears on screen.
- d) exit factory menu.

4.5 High voltage check

Note: the main power voltage can affect the high voltage directly, so be sure to let the B+ power voltage accurate. Under any state, the high voltage should not exceed 29.5KV (21" SF CRT).

- a) connect an accurate high voltage meter between the second anode cap of picture tube and ground.
- b) turn on TV and receive testing card signal.
- c) set picture to standard, the high voltage of this receiver see below chart:

High voltage requirement

CRT brand	CRT model	Value of extra high voltage
NOVEL	54SX503Y22-DC01	24.5KV+/-1KV
IRICO	54SX538Y22-DC01	24.5KV+/-1KV
SAMSUNG	A51KQK99X01	25.5KV+/-0.75KV

d) the high voltage should not exceed 27.5KV for YONGXIN/IRICO CRT (28KV for SAMSUNG CRT) with minimum brightness, contrast and color.

4.6 Focus adjustment

- a) receive A12-PHILIPS (NTSC) signal
- b) adjust focus electrode potentiometer on FBT to optimize B area focus of screen.

4.7 White balance adjustment (color temperature $12000^{\circ}\text{K} \pm 8\text{MPCD}$, $X=0.270 \pm 0.008$, $Y=0.283 \pm 0.008$)

- a) receive full white signal, set color is 0
- b) select factory menu3
- c) on the basis of blue gun "BD", select and adjust "RD, GD" item to make white balance respectively at brightness $Y=6\text{cd}/\text{m}^2$, $Y=80\text{cd}/\text{m}^2$ meet standard (color temperature $12000^{\circ}\text{K} \pm 8\text{MPCD}$, $x=0.270 \pm 0.008$, $y=0.283 \pm 0.008$)
- d) If at brightness $Y=6\text{cd}/\text{m}^2$ white balance can not meet standard, you may adjust "RB, GB" item, then repeat step C) until white balance meet standard.

4.8 Field scanning adjustment (fig-2)

- a) Receive PAL-N(50HZ) (or D35) PHILIPS test pattern signal. set user control to "STANDARD" mode (only the unit in South America)
- b) Receive NTSC(or A12) PHILIPS test pattern signal. set user control to "STANDARD" mode (only the unit in North America)
- c) select factory menu1
- d) adjust V-SLOPE menu to let the horizontal center line of test pattern above blanking.
- e) select V-SHIFT menu and adjust to let the vertical center of picture coincide with vertical center of picture tube.
- f) Select V-SIZE menu and adjust to let the vertical reproduction ratio of picture acceptable 8%.
- g) Adjust V.SC to optimise the vertical S correction of picture.
- h) Receive NTSC(60HZ) A-12PHILIPS test pattern signal, repeat step d)~g) above.(only the unit in South America)

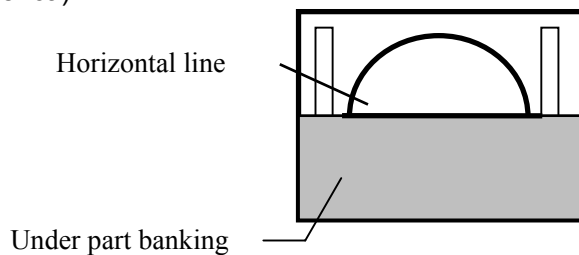

Fig-2 field scan adjustment

4.9 Horizontal scanning adjustment (Fig-3)

- a) Receive PAL-N(50HZ)(or D35) PHILIPS signal, set user control to “STANDARD” mode (only the unit in South America).
- b) Receive NTSC(A12) PHILIPS signal, set user control to “STANDARD” mode (only the unit in North America).
- c) Select factory menu1.
- d) Select H.SHIFT menu and adjust to let the scanning horizontal center coincide with mechanical center of picture tube.
- e) Receive NTSC(60HZ) A12-PHILIPS test pattern signal, repeat step d) above.(only the unit in South America).
- f) Exit factory menu.

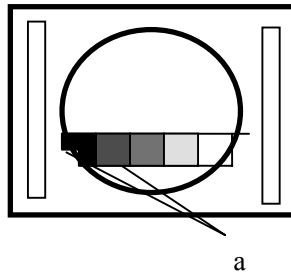

Fig-3 line scan adjustment

4.10 Sub-brightness adjustment

- a) Receive A12-PHILIPS(NTSC) signal
- b) Select “SB” of factory menu3
- c) Adjust “SB” to let things between the fourth and fifth grey scale clear. See Fig-3.

4.11 OSD adjustment

- a) Receive PAL-N(50HZ) or D35-PHILIPS signal.(only the unit in South America).
- b) Select and adjust OSD V.POS and H.POS of factory menu4. Let OSD at a specified place. (only the unit in South America).
- c) Receive NTSC(60HZ) A12-PHILIPS signal.
- d) Select and adjust OSD V.POS and H.POS of factory menu4. Let OSD at a specified place.
- e) Exit factory menu

5. Checking point

5.1 High voltage check

- 1) Connect High Voltage meter between CRT second anode and GND.
- 2) Receive A7 signal, set the control to “STANDARD”, measure the high voltage value, the reading should be $24.5 \text{ kV} \pm 1.0 \text{ kV}$ for NOVEL/IRICO CRT ($25.5 \text{ kV} \pm 0.75 \text{ kV}$ for SAMSUNG CRT)
- 3) Set the brightness and contrast to minimum (zero beam current), measure the high voltage, the reading should not exceed 27.5 kV for NOVEL /IRICO CRT (28 kV for SAMSUNG CRT).

5.2 CRT filament voltage check

Receive A7 signal, set user control to “STANDARD” mode, use effective voltage meter to measure CRT filament voltage, the reading should be $(6.3 \pm 0.3) \text{ Vrms}$

5.3 X-ray protection check

- 1) Receive A7 signal, set user control to “STANDARD” mode.
- 2) Use voltameter to measure TP2 to GND voltage, the reading should be between $15.8 \text{ V} \sim 16.8 \text{ V}$.
- 3) Use 300Ω resistor to touch the two terminals of TP2 ,TP3, X-Ray protection circuit should function, at this time the TV set should be without raster, without sound.

5.4 Picture and sound check

- 1) Receive standard TV signal.
- 2) Use picture control buttons to check color, contrast, brightness, sharpness, tint's function.
- 3) Use sound control buttons to check volume control function.

5.5 MTS STEREO check(if the unit has MTS STEREO function)

- 1) Receive appropriate TV signal.
- 2) Use STEREO button on remote control to check MONO, STEREO, SAP function.

5.6 Sub-brightness check

Receive A7 signal, set brightness to 50, contrast to 50, color to 0, sharpness to 50, picture left side 1-6 lattices slightly light up, things between the sixth and seventh grey scale clear.

5.7 Color purity and convergence check (in normal way)

5.8 AV terminals IN/OUT check, S-VIDEO in check, Y,Cb,Cr in check.

5.9 Other buttons on the TV set and remote controller function check.

5.10 CCD function check: receive CCD signal, it should not lack character at 50dB

5.11 Degaussing

- a) The unit has an auto degaussing circuit, the degaussing circuit works several seconds after turning on TV
- b) If you want to move TV or change the direction, turn off TV and twenty minutes later the degaussing circuit will work
- c) For better degaussing effect, you can use magnetic eraser
- d) Move the magnetic eraser clockwise before your TV, when it is 2m away from your TV, turn off the magnetic eraser. If the effect is still not very good, you can adjust "color purity" and "convergence"

5.12 Color purity correction

- a) Turn on your TV
- b) At least 15 minutes later, use anti-magnetized coil for degaussing
- c) Obtain maximum brightness and contrast
- d) Select factory menu3 and adjust to let R and B be zero, then let only green raster appear on the screen at the moment
- e) Loosen screws of deflection yoke frame to let vertical green belt appear on screen only
- f) Move the rubber wedge
- g) Rotate along neck of picture tube and slide color-purity magnets until the green belt at the middle of screen and is vertical at the same time
- h) Slowly move the deflection yoke backward or forward until the whole green raster appears on screen, tighten the screws of the deflection yoke
- i) Check the color purity of red raster and blue raster
- j) Adjust white balance again to obtain white raster

5.13 Convergence correction

5.13.1 Central convergence correction

- a) Turn on your TV
- b) At least 15 minutes later, receive square test pattern signal
- c) Adjust brightness and contrast to get the best picture
- d) Adjust the angle of two tetrode magnetic rings to let the red vertical line coincide with the blue vertical line at middle of screen
- e) Keep the angle unchanged, move the two tetrode magnetic rings at the same time to let the red and blue horizontal lines coincide at middle of screen

f) Adjust two hexode magnetic rings to let the green line coincide with the mixed line of red and blue. Adjust the angle between them will affect the vertical line, move them together will affect the horizontal line.

g) Repeat d), e), f) and observe the movement of red, green and blue.

5.13.2 Ambient convergence correction

a) Turn on your TV

b) At least 15 minutes later, loosen the screws of the deflection yoke

c) Fixate the rubber wedge temporarily under the deflection yoke

d) Move the deflection yoke upward or downward to get best convergence, push the rubber wedge into space between picture tube and deflection yoke to fixate the deflection yoke temporarily

e) Place the rubber wedge whose overlay paper has been removed at the bottom space

f) Move the deflection yoke left and right to get best convergence

g) Keep the condition unchanged, place another rubber wedge whose overlay paper has been removed also at the upper space at the same time

h) Remove the interim rubber wedge, adhere it to picture tube and deflection yoke

i) After placing three rubber wedges, check all the convergence again

j) Stick three transparent viscous belts to the rubber wedge

6. Software adjustment instructions

6.1 instructions

For the unit in North America, this software contain MTS (option), English, Frence, Spanish and Potugues of OSD(some only has three OSD), CCD and Parental Control function, FS tuner mode, 181 channel.

For the unit in South America, this software contain MTS (option), English, Spanish and Potugues of OSD, CCD and Child Lock function, FS tuner mode, 181 channel.

6.2 factory adjustment mode see Chart 1, Chart 2, Chart 3

6.3 turn on the unit in the STANDBY state

Press CH+/CH- buttons turn on in the STANDBY state.

6.4 Information of software version

Enter MEU9 of the factory menu in the top.

6.5 "STANDARD", "COLORFUL" and " SOFTNESS" setting

a).Enter MENU5 Mode of the factory menu

b).charge their for seemly analog quantity, then return standard option.

Chart 1: I²C NOM8377-B-8NB E²PROM pre-set data (IRICO/YONGXIN CRT)

MI	Items	Range	Preset
M0	SUBCON	0-63	58 (sub-contrast)
	SUBCOL	0-63	56 (sub-chroma)
	SUBSHP	0-63	48(42-48) (sub-acutance)
	SUBTINT	0-63	31(sub-hue)
M1	V.SLOPE	0-63	36(field center adjustment)
	V.SHIFT	0-63	32(field point adjustment)

MI	Items	Range	Preset
	V.SIZE	0-63	36(field amplitude adjustment)
	V.SC	0-63	32(field line)
	HSHIFT	0-63	32(line point adjustment)
	PROGRAMA.NO		2(channel)
M2	AGCTAKE OVER	0-63	23(AGC adjustment)
	SHIPPING		0(leave factory set)
M3	BT	0-100	75(adjust white balance of brightness)
	CT	0-100	75(adjust white balance of brightness contrast)
	SC		0
	RB	0-63	32(red cut off level adjustment)
	GB	0-63	32(green cut off level adjustment)
	RD	0-63	32(red drive level adjustment)
	GD	0-63	32(green drive level adjustment)
	BD	0-63	32(blue drive level adjustment)
	SB	0-63	40(sub brightness adjustment)
M4	OSD.V.POSITION	0-63	15(OSD position)
	OSD.H.POSITION	0-63	25(OSD H-position)
	BTSC-MODE	MONO/STEREO	MONO(STEREO/SAP selection)
	BTSC-ST	0-15	13
	BTSC-SP	0-15	12
	BTSC-L1	0-15	6(5-6)
	BTSC-A1	0-31	12
	BTSC-A2	0-31	0
	BTSC-TC	0-7	0
	BTSC-STS	0-1	0
	BTSC-ADJ		
M5	MODE		STANADARD (standard, soft, floweriness)
	BRIGHT	0-100	75
	CONTRAST	0-100	75
	COLOR	0-100	50
	SCBRIGHT	0-63	23(20-28)
	YDELAYTV	0-15	12
	YDELAYAV	0-15	12
M6	OSO	0-1	1(field over-scan switch)
	AGCSPEED	0-3	2(AGC of speed)
	FFI	0-1	0(IF PLL SPEED)
	FMWS	0-1	1(frequency range of sound OFF=225KHZ,ON=450KHZ)

MI	Items	Range	Preset
	RP0	0-3	0(pre-shock and over-shock scale)
	NTSCMATRIX	USA/JAPAN	USA
	VOLPIN	0-1	0(1:push-pull output; 0: OC gate output.)
	SOFT CLIP	0-3	3(white level limit)
	PEAK WHITE	0-15	15(peak white limit)
	CORING	0-1	0(coring noise reduction)
M7	AV2	0/1	1
	SVHS	0/1	1
	YUV	0/1	1
	BLUE SCREEN	0/1	1
	VOLADJPOING		1(volume value have: 1, 25, 50, 75)
	VOLVALUE		20(volume curve value: 35, 70, 80, 90)
M8	CATHOOELEVEL	0-15	7 (cathode level)
	UOCVOLUME	0/1	0(0:PWM control 1:UOC internal audio amplify control)
	FMATT	0-63	45(UOC sound output of amplitude) BTSC : 38
	COMB FILTRE	0/1	0(NTSC comb filter)
	HEADPHONE	0-2	0(select headphone function)
	VM OPTION	0/1	0(select VM function)
	FRANCE	0/1	1 French
	SPANISH	0/1	1 Spanish
	POTUGUES	0/1	0 Portuguese
M9	NOM8377-B-8NB		
	STARTON	0-2	2(turn on)
	START TIME	6-15	8(turn on time)
	IF OFFSET	0-63	32(IF compensate)
	TUNER	0-2	0(BXATB011F---X/ BXATB108F---K/ BXATB015F---X/ BXATB021F---D), 1 (BXATB017F---K) ,2(XXX)
	CALENDAR	0-1	0
	GAME	0-1	0
	LOGO	0-1	0

Chart 2: I²C NOM8377-B-9NA/ NOM8377-B-9NB E²PROM pre-set data (IRICO/YONGXIN CRT)

MI	Items	Range	Preset
M0	SUBCON	0-63	58 (sub-contrast)
	SUBCOL	0-63	56 (sub-chroma)
	SUBSHP	0-63	48(42-48) (sub-acutance)
	SUBTINT	0-63	31(sub-hue)

MI	Items	Range	Preset
M1	V.SLOPE	0-63	36(field center adjustment)
	V.SHIFT	0-63	32(field point adjustment)
	V.SIZE	0-63	36(field amplitude adjustment)
	V.SC	0-63	32(field line)
	HSHIFT	0-63	32(line point adjustment)
	PROGRAMA.NO		2(channel)
M2	AGCTAKE OVER	0-63	23(AGC adjustment)
	SHIPPING		0(leave factory set)
	YUV HS.OFFSET	0-15	8(only NOM8377-B-9NB)
M3	BT	0-100	75(adjust white balance of brightness)
	CT	0-100	75(adjust white balance of brightness contrast)
	SC		0
	RB	0-63	32(red cut off level adjustment)
	GB	0-63	32(green cut off level adjustment)
	RD	0-63	32(red drive level adjustment)
	GD	0-63	32(green drive level adjustment)
	BD	0-63	32(blue drive level adjustment)
	SB	0-63	40(sub brightness adjustment)
M4	OSD.V.POSITION	0-63	15(OSD position)
	OSD.H.POSITION	0-63	25(OSD H-position)
	BTSC(AN5832)-AGC	0-1	1
M5	MODE		STANADARD (standard, soft, floweriness)
	BRIGHT	0-100	75
	CONTRAST	0-100	75
	COLOR	0-100	50
	SCBRIGHT	0-63	23(20-28)
	YDELAYTV	0-15	12
	YDELAYAV	0-15	12
M6	OSO	0-1	1(field over-scan switch)
	AGCSPEED	0-3	2(AGC of speed)
	FFI	0-1	0(IF PLL SPEED)
	FMWS	0-1	1(frequency range of sound OFF=225KHZ,ON=450KHZ)
	RP0	0-3	0(pre-shock and over-shock scale)
	NTSCMATRIX	USA/JAPAN	USA
	VOLPIN	0-1	0(1:push-pull output; 0: OC gate output.)
	SOFT CLIP	0-3	3(white level limit)

MI	Items	Range	Preset
	PEAK WHITE	0-15	15(peak white limit)
	CORING	0-1	0(coring noise reduction)
M7	AV2	0/1	1
	SVHS	0/1	1
	YUV	0/1	1
	BLUE SCREEN	0/1	1
	VOLADJPOING		1(volume value have: 1, 25, 50, 75)
	VOLVALUE		20(volume curve value: 35, 70, 80, 90)
M8	CATHOOELEVEL	0-15	7 (cathode level)
	UOCVOLUME	0/1	0(0:PWM control 1:UOC internal audio amplify control)
	FMATT	0-63	45(UOC sound output of amplitude) BTSC : 28
	COMB FILTRE	0/1	0(NTSC comb filter)
	HEADPHONE	0-2	0(select headphone function)
	VM	0/1	0(select VM function)
	FRANCE	0/1	1 French
	SPANISH	0/1	1 Spanish
	POTUGUES	0/1	0 Portuguese
M9	NOM8377-B-9NA/9NB		
	STARTON	0-2	2(turn on)
	START TIME	6-15	8(turn on time)
	IF OFFSET	0-63	32(IF compensate)
	TUNER	0-2	0(BXATB011F---X/ BXATB108F---K/ BXATB015F---X/ BXATB021F---D), 1 (BXATB017F---K),2(XXX)
	CALENDAR	0-1	0
	GAME	0-1	0
	LOGO	0-2	0
	LOGO TIME	1-15	6

Chart 3: I²C NOM8377-B-9NA/9NB E²PROM pre-set data (SAMSUNG CRT)

MI	Items	Range	Preset
M0	SUBCON	0-63	55 (sub-contrast)
	SUBCOL	0-63	50 (sub-chroma)
	SUBSHP	0-63	48 (sub-acutance)
	SUBTINT	0-63	32(sub-hue)
M1	V.SLOPE	0-63	36(field center adjustment)

MI	Items	Range	Preset
	V.SHIFT	0-63	43(field point adjustment)
	V.SIZE	0-63	22(field amplitude adjustment)
	V.SC	0-63	28(field line)
	H.SHIFT	0-63	37line point adjustment)
	PROGRAMA.NO		12 (channel)
M2	AGC TAKE OVER	0-63	23(AGC adjustment)
	SHIPPING		0(leave factory set)
	YUV HS.OFFSET	0-15	8 (only NOM8377-B-9NB)
M3	BT	0-100	75(adjust white balance of brightness)
	CT	0-100	75(adjust white balance of brightness contrast)
	SC		0
	RB	0-63	32(red cut off level adjustment)
	GB	0-63	32(green cut off level adjustment)
	RD	0-63	32(red cut off level adjustment)
	GD	0-63	32(green cut off level adjustment)
	BD	0-63	32(blue cut off level adjustment)
	SB	0-63	40(sub brightness adjustment)
M4	OSD.V.POSITION	0-63	15(OSD position)
	OSD.H.POSITION	0-63	25(OSD H-position)
	BTSC-AGC	0-1	1 BTSC(MTS) 0 NOTHING
M5	MODE		STANADARD (standard, soft, floweriness)
	BRIGHT	0-100	75
	CONTRAST	0-100	75
	COLOR	0-100	50
	SC BRIGHT	0-63	30
	YDELAYTV	0-15	8
	YDELAYAV	0-15	8
M6	OSO	0-1	1(field over-scan switch)
	AGCSPEED	0-3	2(AGC of speed)
	FFI	0-1	0(IF PLL SPEED)
	FMWS	0-1	1(frequency range of sound OFF=225KHZ,ON=450KHZ)
	RP0	0-3	0(pre-shock and over-shock scale)
	NTSCMATRIX	USA/JAPAN	USA
	VOLPIN	0-1	0(1:push-pull output; 0: OC gate output.)
	SOFT CLIP	0-3	3(white level limit)
	PEAK WHITE	0-15	15(peak white limit)
	CORING	0-1	0(coring noise reduction)

MI	Items	Range	Preset
M7	AV2	0/1	1
	SVHS	0/1	1
	YUV	0/1	1
	BLUE SCREEN	0/1	1
	VOLADJPOING		1(volume value have: 1, 25, 50, 75)
	VOLVALUE		20(volume curve value: 35, 70, 80, 90)
M8	CATHOO ELEVEL	0-15	6 (cathode level)
	UOCVOLUME	0/1	0(0:PWM control 1:UOC internal audio amplify control)
	FMATT	0-63	45(UOC sound output of amplitude) BTSC : 28
	COMB FILTRE	0/1	0(NTSC comb filter)
	HEADPHONE	0-2	0(select headphone function)
	VM	0/1	0(select VM function)
	FRANCE	0/1	1 French
	SPANISH	0/1	1 Spanish
	POTUGUES	0/1	0 Portuguese
M9	NOM8377-B-9NA/9NB		
	STARTON	0-2	2(turn on)
	START TIME	6-15	8(turn on time)
	IF OFFSET	0-63	32(IF compensate)
	TUNER	0-2	0(BXATB011F---X/BXATB108F---K/BXATB015F---X/BXATB021F---D), 1 (BXATB017F---K),2(XXX)
	CALENDAR	0-1	0
	GAME	0-1	0
	LOGO	0-2	0
	LOGO TIME	1-15	6

Block diagram

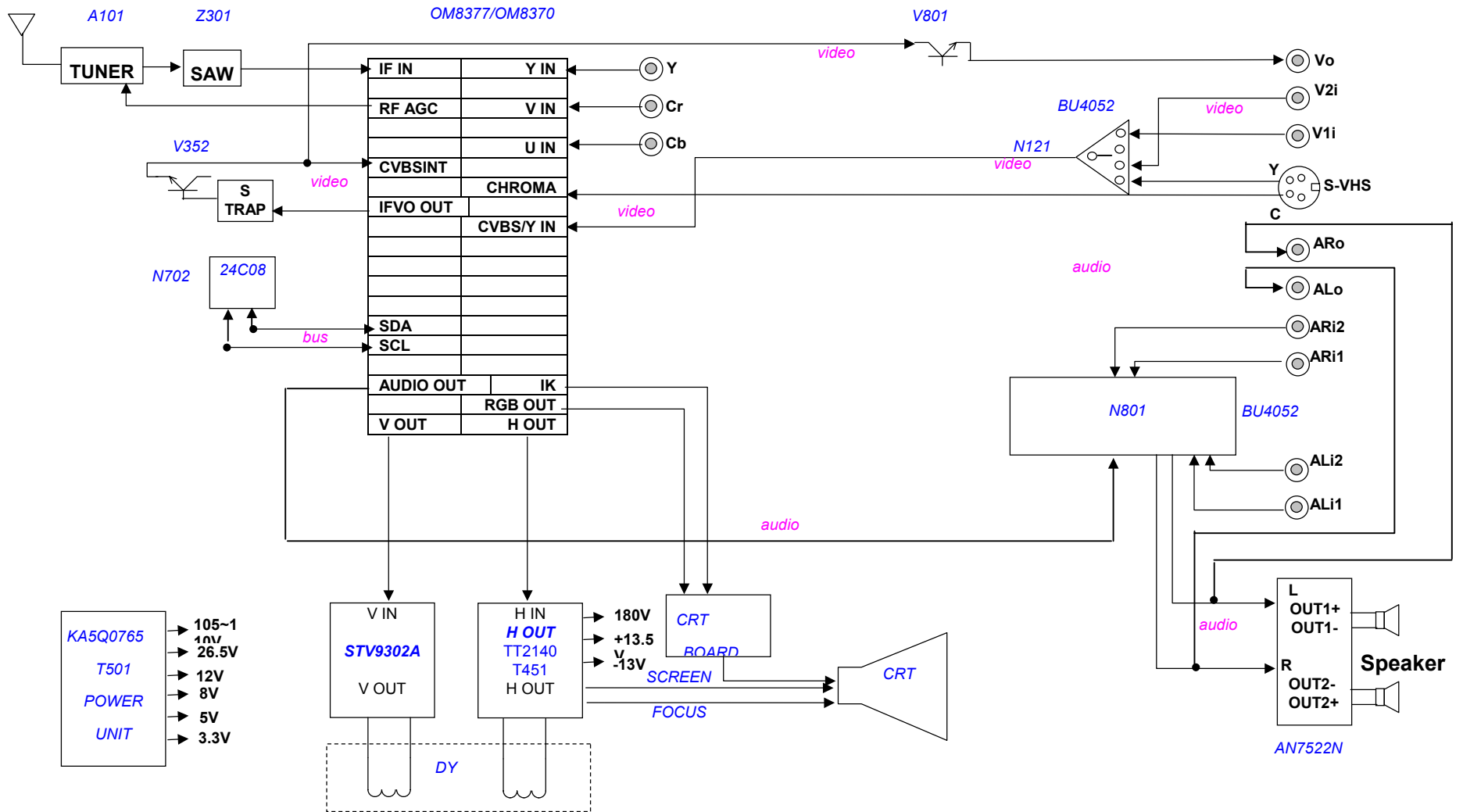

IC block diagram

OM8370(South America) / OM8377(North America) (NO PAL DECODER)

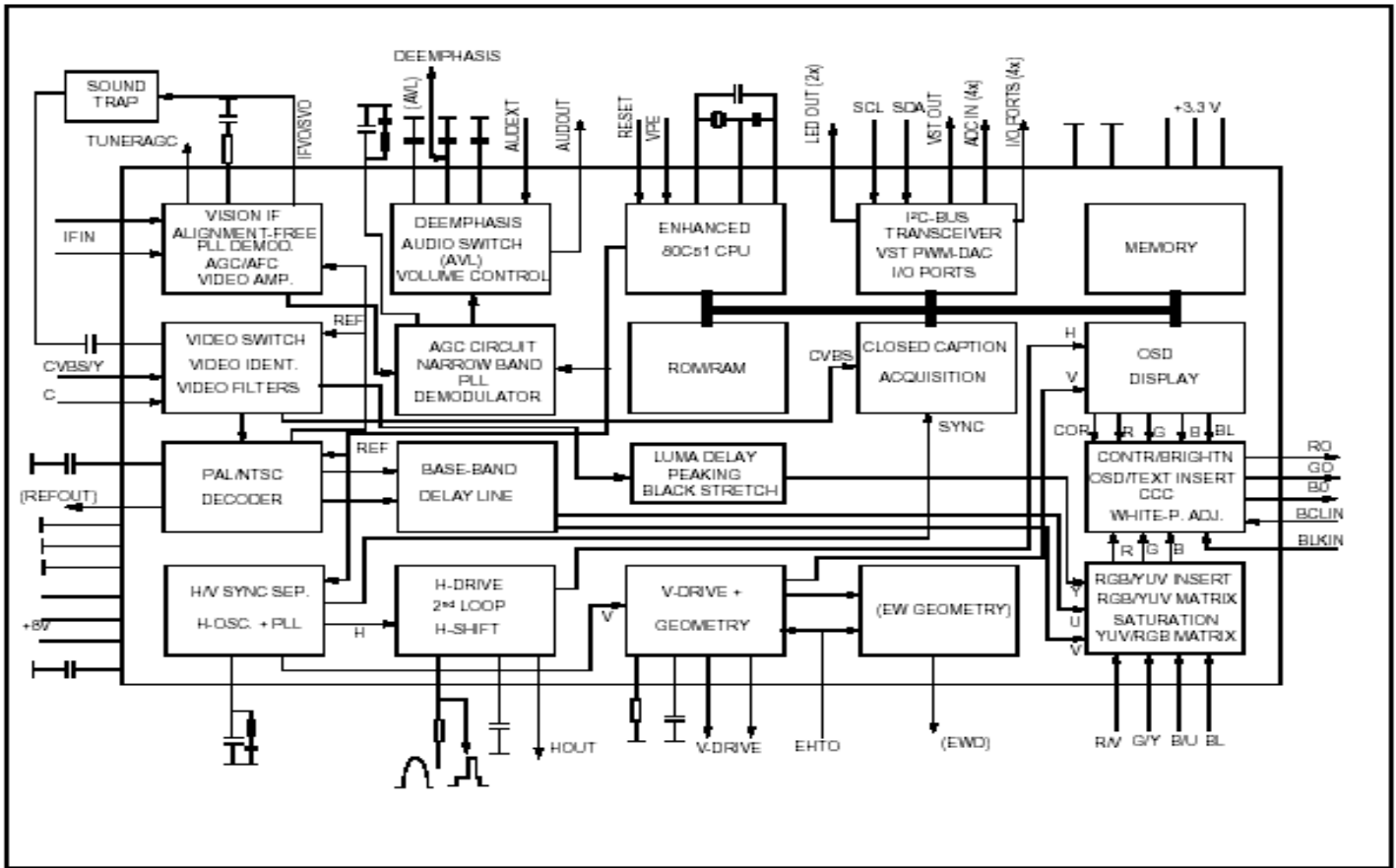

ICs functional description

UOC OM8377 / OM8370

SYMBOL	PIN	DESCRIPTION
STAND BY output.	1	In STAND BY mode, high level (Power OFF). For Power ON this pin will be reduced to low. (NOM8377-B-8NB/9NA)
SCL	2	I ² C-bus clock line
SDA	3	I ² C-bus data line
TUNING	4	NC
P3.0/ STAND BY output	5	In STAND BY mode, high level (Power OFF). For Power ON this pin will be reduced to low. (NOM8377-B-9NB)
KEY	6	Control keys input
VOL	7	Sound Volume control PWM output
MUTE	8	Sound mute output
VSSC/P	9	Digit ground for μ-controller core and periphery
BAND1	10	NC
BAND2	11	NC
VSSA	12	Analog ground of teletext decoder and digital ground of TV-processor
SECPLL	13	PLL decoupling
VP2	14	2 nd supply voltage TV-processor(+8V)

SYMBOL	PIN	DESCRIPTION
DECDIG	15	decoupling digital supply of TV-processor
PH2LF	16	Phase-2 filter
PH1LF	17	Phase-1 filter
GND3	18	Ground 3 for TV-processor
DECBG	19	Band gap decoupling
AVL/EWD	20	Automatic volume leveling /EAST-WEST drive output
VDRB	21	Vertical drive B output
VDRA	22	Vertical drive A output
IFIN1	23	IF input 1
IFIN2	24	IF input 2
IREF	25	Reference current input
VSC	26	Vertical sawtooth capacitor
TUNER AGC	27	Tuner AGC output
AUDEEM/SIFIN1 *1	28	Audio deemphasis or SIF input
DECSDEM/SIFIN2	29	decoupling sound demodulator or SIF input 2
GND2	30	ground 2 for TV processor
SNDPLL/SIFAGC *1	31	narrow band PLL filter or AGC sound IF
AVL/SNDIF/REF0/ AMOUT *1	32	Automatic Volume Levelling / sound IF input / subcarrier reference output / audio deemphasis
HOUT	33	horizontal output
FBISO	34	flyback input/sandcastle output
AUDEXT/QSSO/ AMOUT *1	35	external audio output / QSS intercarrier out
EHTO	36	EHT/overvoltage protection input
PLL IF	37	IF-PLL loop filter
IFVO/SVO	38	IF video output / selected CVBS output
VP1	39	supply voltage TV processor
CVBS INT	40	internal CVBS input
GND1	41	ground for TV processor
CVBS/Y	42	CVBS/Y input
CHROMA	43	C input
AUDOUT/AMOUT *1	44	audio output /AM audio output (volume controlled)
INSSW2	45	2nd RGB / YUV insertion input
R2/VIN	46	2nd R input / V (R-Y) input / PR input
G2/YIN	47	2nd G input / Y input
B2/UIN	48	2nd B input / U (B-Y) input / PB input
BCLIN	49	beam current limiter input
BLKIN	50	black current input / V-guard input
RO	51	Red output
GO	52	Green output
BO	53	Blue output

SYMBOL	PIN	DESCRIPTION
VDDA	54	analog supply of Closed Caption decoder and digital supply of TV-processor (3.3 V)
VPE	55	OTP Programming Voltage
VDDC	56	digital supply to core (3.3 V)
OSCGND	57	oscillator ground supply
XTALIN	58	crystal oscillator input
XTALOUT	59	crystal oscillator output
RESET	60	reset
VDDP	61	digital supply to periphery (+3.3 V)
P1.0/INT1	62	TV/AV (AV1) / AV2 /S-VHS mode Output.
P1.1/T0	63	TV/AV (AV1) / AV2 /S-VHS mode Output.
P1.2/INT0	64	Remote control signal input.

AN7522N / AN17821A Function : **audio output**

Symbol	PIN	Function	Symbol	PIN	Function
Vcc	1	Power supply	GND	7	ground
Out 1 (+)	2	Ch 1 output (+)	In 2	8	Ch 2 input
GND(out 1)	3	Ch 1Ground	VOL	9	Volume Control
Out 1 (-)	4	Ch 1 output (-)	Out 2 (-)	10	Ch 2 output (-)
Standby	5	Mute input	GND(out 2)	11	Ch 2 Ground
In 1	6	Ch 1 input	Out 2 (+)	12	Ch 2 output (+)

STV9302A / LA78040 Function : **vertical output**

Symbol	PIN	Function	Symbol	PIN	Function
INV IN	1	Input	V OUT	5	Vertical output
VCC1	2	Power	VCC2	6	Output power supply
PUMP UP	3	Pump up power	NON INV IN	7	Negative feedback
GND	4	Ground			

IC voltages

OM8377 / OM8370

PIN	1	2	3	4	5	6	7	8	9	10	11	12	13	14	15	16
V	2.8	3.8	3.6	3.3	3.5	3.5	0.1	0.1	0	5.4	0.1	0	2.3	8	5	3
PIN	17	18	19	20	21	22	23	24	25	26	27	28	29	30	31	32
V	4	0	4	0.9	0.7	0.8	1.9	1.9	3.9	3.8	1.6	3.2	3.4	0	2.4	0.1
PIN	33	34	35	36	37	38	39	40	41	42	43	44	45	46	47	48
V	0.6	0.5	3.7	1.7	2.4	3.1	8	3.8	0	3.4	1.5	3.6	2.3	2.6	2.6	2.6
PIN	49	50	51	52	53	54	55	56	57	58	59	60	61	62	63	64
V	2.3	7.2	2.7	2.7	2.7	3.5	0	3.5	0.1	1.7	1.8	0	3.5	0.1	0.1	5

STV9302A / LA78040

PIN	1	2	3	4	5	6	7
V	0.7	15	-12	-15	0.3	15.9	-0.07

AN 7522N / AN17821A

PIN	1	2	3	4	5	6	7	8	9	10	11	12	
V	12	7	0	7	3.3	1.4	0	1.4	0	7	0	7	

6. Test point Waveforms

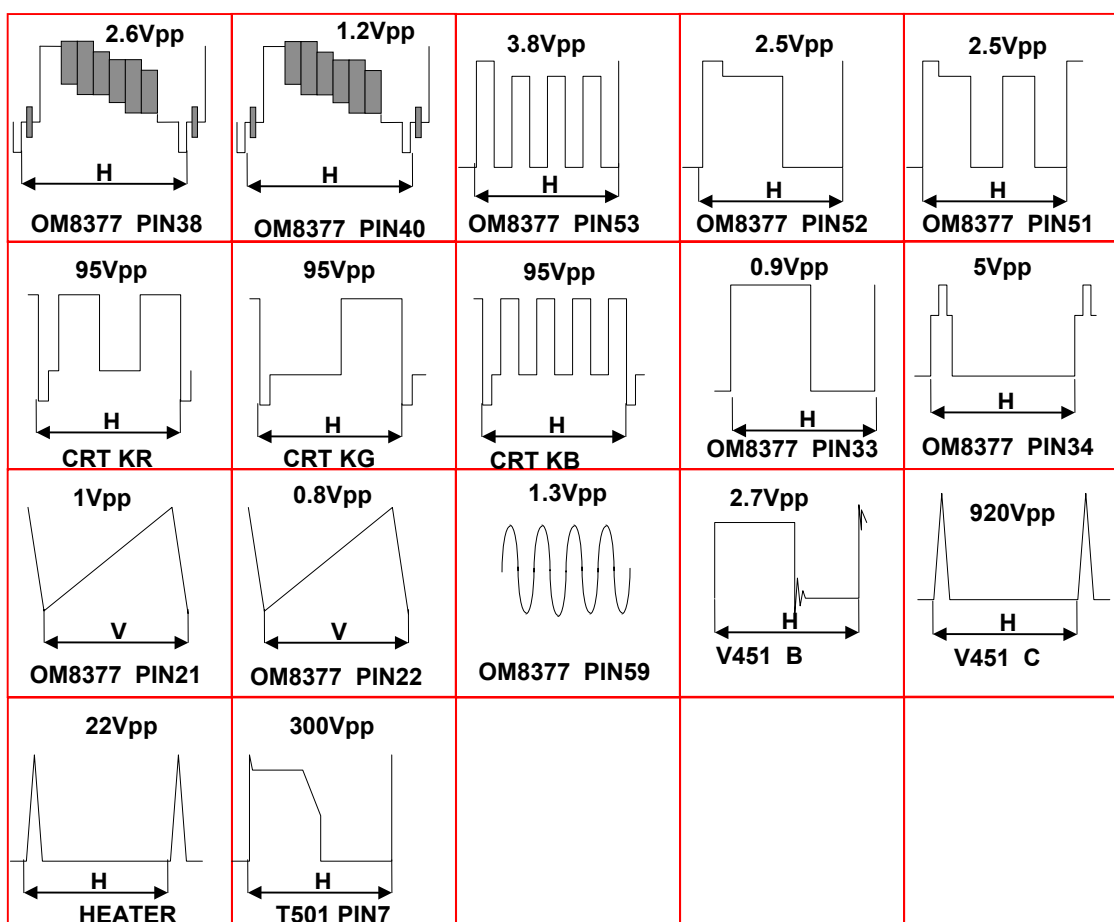

Wiring diagram

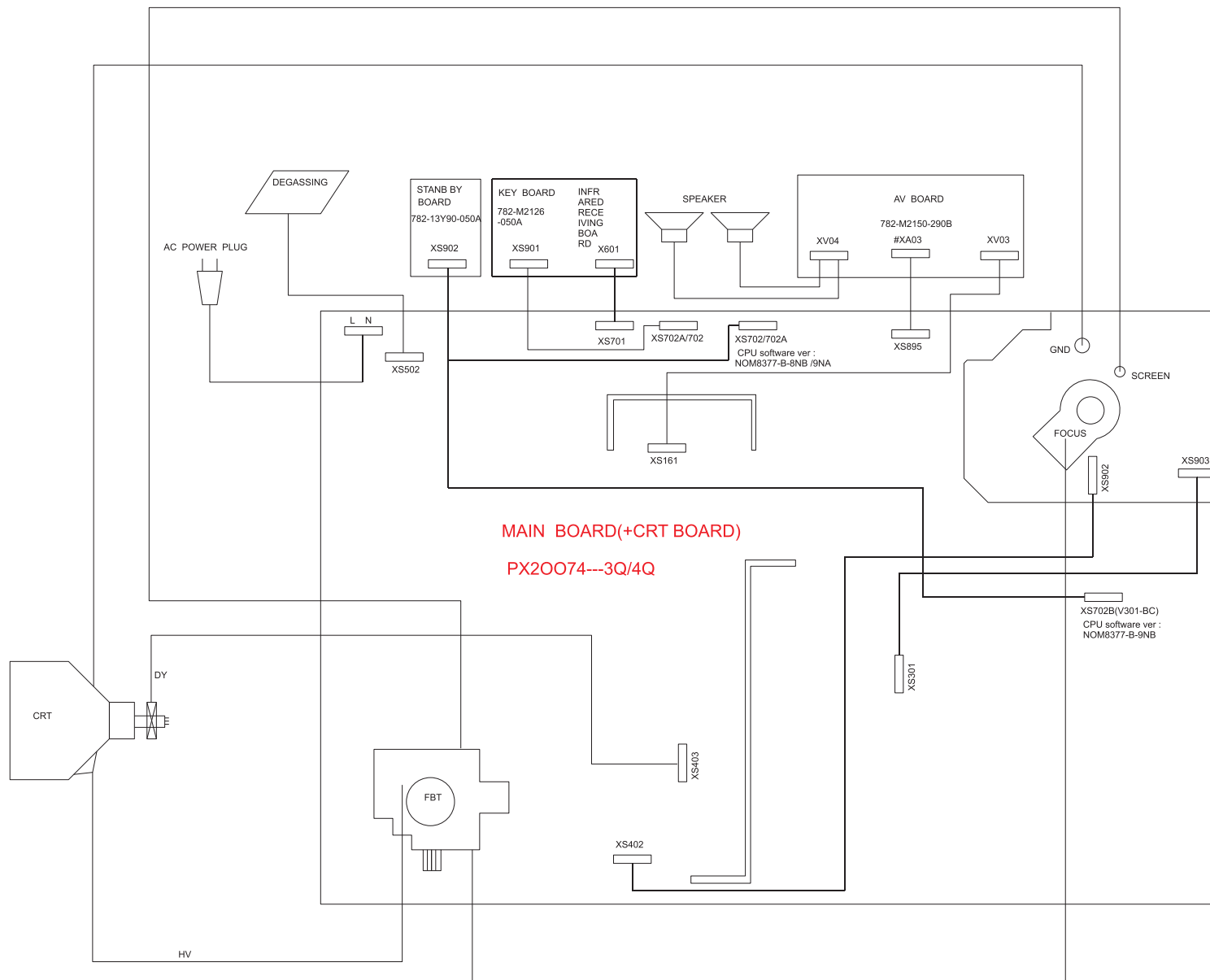

203-TK20260-12JL

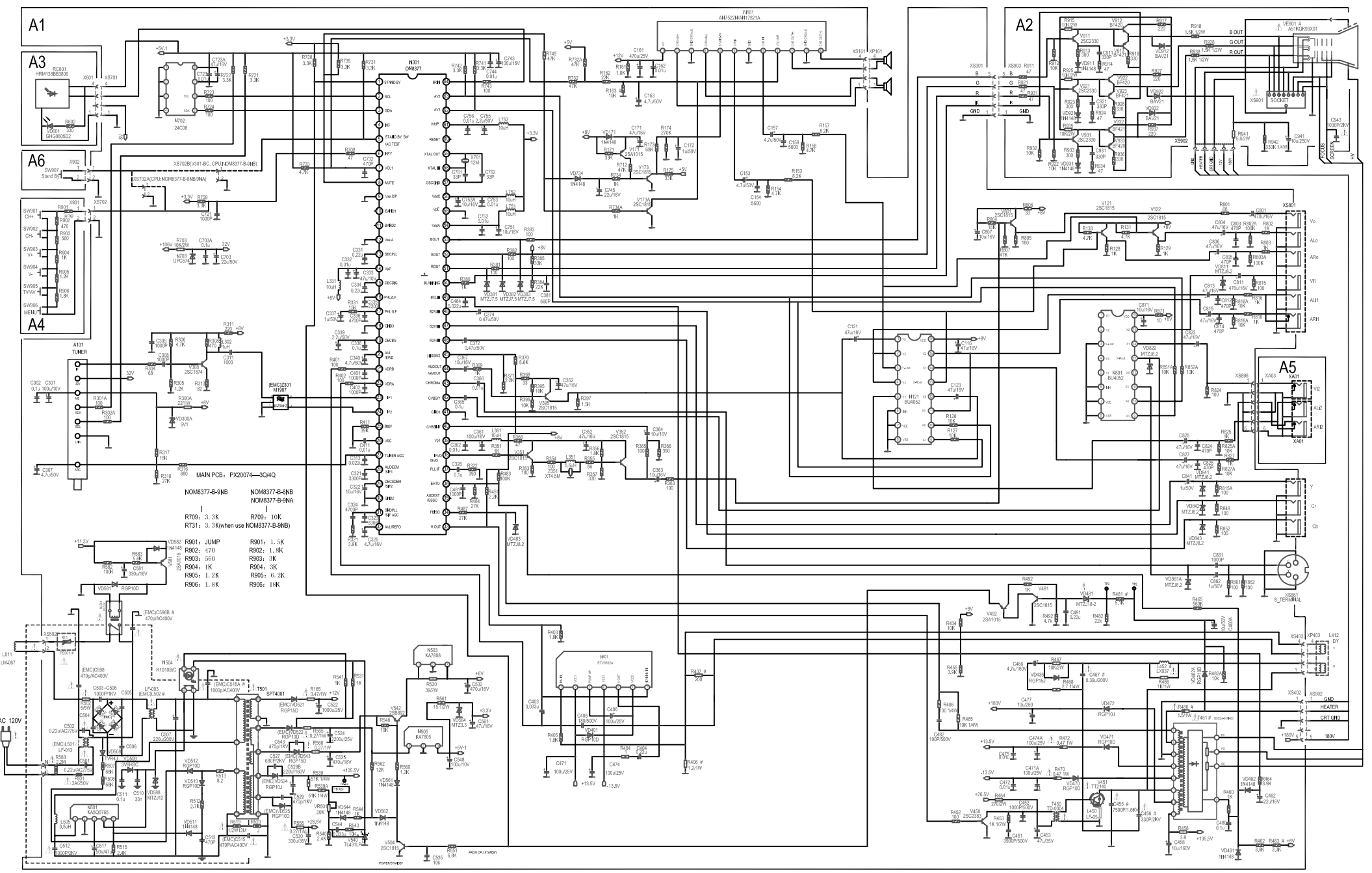

MAIN PCB: PX20074-3Q4C
 NOM8377-B-9NB
 NOM8377-B-9NA
 R709: 3.3K
 R731: 3.3K (when use NOM8377-B-9NB)
 R709: 3.3K
 R709: 10K
 R731: 3.3K (when use NOM8377-B-9NB)
 R901: 1.5K
 R902: 1.5K
 R903: 3K
 R904: 3K
 R905: 6.2K
 R906: 1.8K

